

## FORD POLICE INTERCEPTOR DOME LIGHT RED LED/CLEAR INCANDESCENT MODEL ECVDMLTCV AND WHITE/RED LED MODEL ECVDMLTALCV

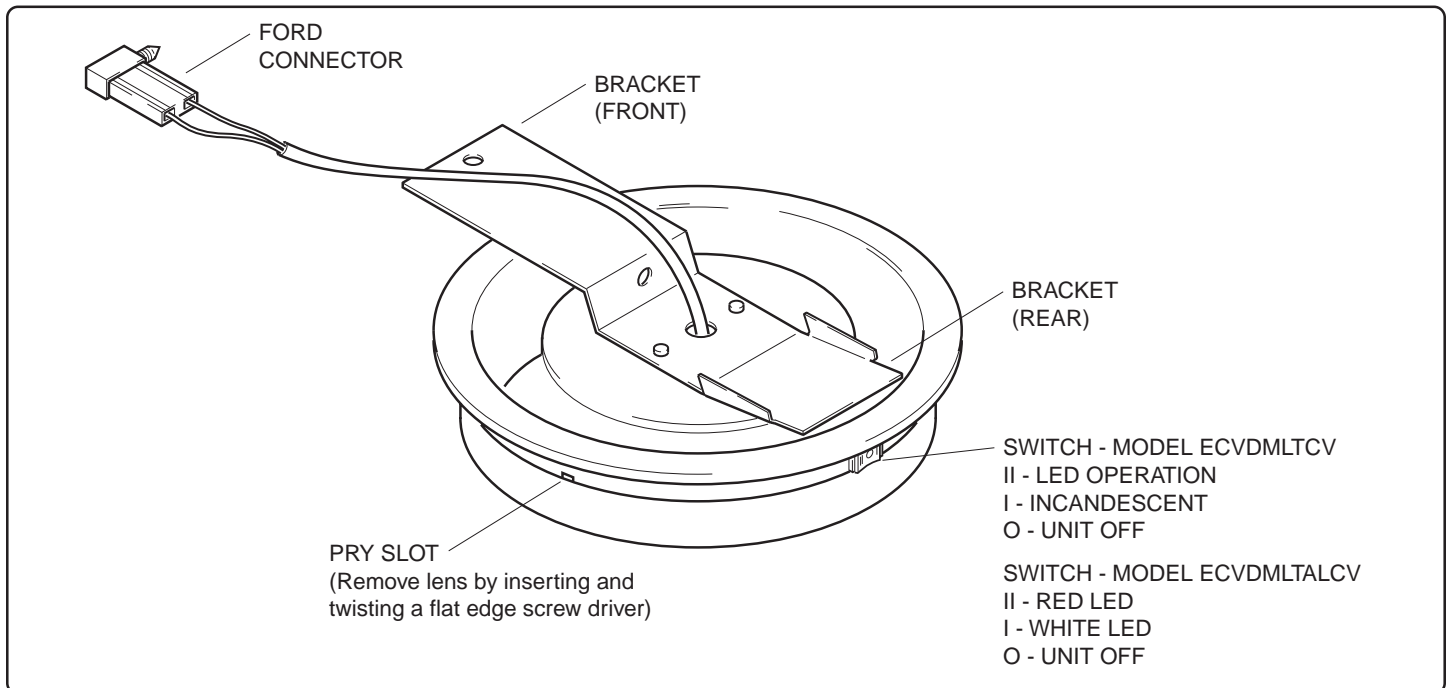

### REMOVAL

1. Gently pull down Headliner in front of Dome Light.
2. Reach in and find the front edge of the light mounting bracket.
3. Pull straight down to loosen the push pin that secures the light to the Headliner.
4. Pull the light forward to loosen the back bracket and then push the light all the way back. This will let the front part of the bracket through the hole in the Headliner.
5. Remove the light.
6. Unplug the light from the vehicle wiring harness.

### INSTALLATION

1. Follow the procedure listed above, only in reverse, to install the SoundOff Signal Police Dome Light.
2. Secure the Dome Light by replacing the OEM push pin.

### HARD WIRE OPTION

1. Connect the SoundOff Signal Dome Light's BLACK wire to the vehicle ground wire.
2. Connect the SoundOff Signal Dome Light's WHITE wire to a vehicle positive wire.

### MODEL ECVDMLTCV "ONLY" NOTE

DO NOT exceed wattage of factory supplied bulb.

#### Incandescent Replacement Bulb:

Philips #12854  
SOI #PDMLTB10

Technical Support: 1-800-338-7337

### WARRANTY

SoundOff Signal warrants the ECVDMLTCV & ECVDMLTALCV Ford Police Interceptor Dome Lights for 1 (full) year (5 years on the LED lights) from the date of purchase to the original purchaser against any manufactured defects or workmanship. This warranty applies only to units installed according to manufacturer's instructions and operated within the units specifications. SoundOff Signal's obligation under this warranty is limited to repairing or exchanging the unit.

Warranty claims should be returned directly to SoundOff Signal: Attention Warranty/Repair Department for consideration.