

WHELEN[®] ENGINEERING COMPANY INC.

51 Winthrop Road
 Chester, Connecticut 06412-0684
 Phone: (860) 527-9504
 Fax: (860) 527-4078
 Internet: www.whelen.com
 Sales e-mail: autosale@whelen.com
 Canadian Sales e-mail: autocan@whelen.com
 Customer Service e-mail: custserv@whelen.com

Installation/Operating Guide Programmable Hand-Held Siren/ Light Control System Model HHS2200

DANGER! Sirens produces extremely loud emergency warning tones! Exposure to these tones without proper and adequate hearing protection, could cause ear damage and/or hearing loss! The Occupational Safety & Health Administration (www.osha.gov) provides information necessary to determine safe exposure times in Occupational Noise Exposure Section 1910.95. Until you have determined the safe exposure times for your specific application, operators and anyone else in the immediate vicinity should be required to wear an approved hearing protection device. **FAILURE TO FOLLOW THIS RECOMMENDATION COULD CAUSE HEARING LOSS!**

Safety First

This document provides all the necessary information to allow your Whelen product to be properly and safely installed. Before beginning the installation and/or operation of your new product, the installation technician and operator must read this manual completely. Important information is contained herein that could prevent serious injury or damage.

- Proper installation of this product requires the installer to have a good understanding of automotive electronics, systems and procedures.
- If mounting this product requires drilling holes, the installer **MUST** be sure that no vehicle components or other vital parts could be damaged by the drilling process. Check both sides of the mounting surface before drilling begins. Also de-burr any holes and remove any metal shards or remnants. Install grommets into all wire passage holes.
- If this manual states that this product may be mounted with suction cups, magnets, tape or Velcro™, clean the mounting surface with a 50/50 mix of isopropyl alcohol and water and dry thoroughly.
- Do not install this product or route any wires in the deployment area of your air bag. Equipment mounted or located in the air bag deployment area will damage or reduce the effectiveness of the air bag, or become a projectile that could cause serious personal injury or death. Refer to your vehicle owners manual for the air bag deployment area. The User/Installer assumes full responsibility to determine proper mounting location, based on providing ultimate safety to all passengers inside the vehicle.
- For this product to operate at optimum efficiency, a good electrical connection to chassis ground must be made. The recommended procedure requires the product ground wire to be connected directly to the **NEGATIVE (-)** battery post.
- If this product uses a remote device to activate or control this product, make sure this control is located in an area that allows both the vehicle and the control to be operated safely in any driving condition. **DO NOT ATTEMPT TO ACTIVATE OR CONTROL THIS DEVICE IN A HAZARDOUS DRIVING SITUATION.**
- It is recommended that these instructions be stored in a safe place and referred to when performing maintenance and/or reinstallation of this product.
- **FAILURE TO FOLLOW THESE SAFETY PRECAUTIONS AND INSTRUCTIONS COULD RESULT IN DAMAGE TO THE PRODUCT OR VEHICLE AND/OR SERIOUS INJURY TO YOU AND YOUR PASSENGERS!**

**ACTIVATION OF THIS
 SIREN MAY DAMAGE
 UNPROTECTED EARS!**



CAUTION

Loud siren noise can cause hearing damage and/or loss. Refer to OSHA Section 1910.95 prior to putting ANY siren into service!

For warranty information regarding this product, visit www.whelen.com/warranty

This Page Intentionally Left Blank

Specifications

General

Input Voltage	12.8 VDC \pm 20%
	Negative Ground Only
Siren Input Current	16 Amps Max.
Siren Input Fuse	20 Amps
Stand-by Current (backlight off)	< 1mA (typ)
Operating Temperature	-30°C to +60°C
Storage Temperature	-40°C to +70°C
Humidity	99% (Non-condensing)

Outlet Current

Outlet #1	10 Amps Max. (fused)
Outlet #2	10 Amps Max. (fused)
Outlet #3	10 Amps Max. (fused)
Outlet #4	10 Amps Max. (fused)
Outlet #5	10 Amps Max. (fused)
Outlet #6	10 Amps Max. (fused)
Outlet #7	10 Amps Max. (fused)
Outlet #8	10 Amps Max. (fused)
Outlet #9	15 Amps Max. (fused)
Outlet #10 (Icon Driver)	250 mA Max. (internally fused)

NOTE: Outlets 1 thru 9 are "Positive Switching". Loads connected to each relay output should be grounded to the battery.

NOTE: Total current of Outlets 1 - 9 not to exceed 75 Amps

Dimensions (Amp/Relay Module)

Height	2.560 inches
Width (incl. mounting flanges)	8.082 inches
Depth	7.275 inches

Dimensions (Control Head)

Height	5.30 inches
Width	2.25 inches
Depth	1.12 inches

Installation

Amp/Relay Module

1. Locate a suitable mounting location. A dry, cool compartment is a good choice.
2. Position the Amp/Relay module on the proposed mounting location. Using an awl or similar tool, scribe the mounting surface where the mounting holes are to be drilled. Make sure that this mounting area allows sufficient ventilation for the Amp/Relay module.

Caution: As mounting the Amp/Relay module will require drilling, it is absolutely necessary to make sure that no other vehicle components could be damaged in the process. Check both sides of the mounting surface before starting. If damage is likely, select a different mounting location.

3. Remove the module from its mounting area, and using a drill bit sized for a #10 sheet metal screw, drill a hole in each of the areas scribed in the previous step.
4. Return the module to its mounting location and using #10x3/4" sheet metal screws (provided), secure the module onto its mounting surface. Be sure to install a #10 internal tooth lock washer (included) onto each mounting screw before mounting the unit. **IMPORTANT:** The amp/relay module case must be either mounted on, or grounded to the vehicle chassis.

Hand-held Controller/Microphone

The system is controlled using a hand-held controller. This controller is comprised of a microphone (with Push-To-Talk key) and 12 illuminated push-buttons.

The mounting bracket for the controller should be located within a comfortable reaching distance from the operator.

IMPORTANT AIR BAG WARNING! Do not install this product or route any wires in the air bag deployment zone of your vehicle. Equipment mounted or located in air bag deployment zones will damage or reduce the effectiveness of the air bag, or become a projectile that could cause serious personal injury or death. Refer to your vehicle owners manual to learn the air bag deployment zones for the vehicle. The User/Installer assumes full responsibility to determine proper mounting location, based on providing ultimate safety to all passengers inside the vehicle.

Wiring

WARNING! All customer supplied wires that connect to the positive terminal of the battery must be sized to supply at least 125% of the maximum operating current and **FUSED** at the battery to carry that load. **DO NOT USE CIRCUIT BREAKERS WITH THIS PRODUCT!**

Refer to the wire chart on page 6 to help determine the required wire sizes needed for each circuit.

NOTE: Item numbers reference the illustration found on page 8.

IMPORTANT! Wires connecting to the Amp/Relay Module have the proper terminals pre-installed from the factory. **WHELEN DOES NOT RECOMMEND RE-TERMINATING ANY WIRES.**

System Power (Items 1-1 thru 1-4)

1. Locate the High-Current Molex™ connector and wires (included) sized to fit into the system power connectors (items 1-1 thru 1-4).
2. Route the BLACK wire (1-1) from the amp/relay module to the NEGATIVE battery terminal.

3. Route the three RED wires (1-2 thru 1-4) from the amp/relay module to the POSITIVE battery terminal. Fuse **each** of these wires as follows:

1-2 (Siren)	20 Amp
1-3 (Relay)	40 Amp
1-4 (Relay)	40 Amp

NOTE: These fuses must be located within 2 wire feet of the battery.

Do not install these fuses into their holders until all wiring connections are completed!

4. Complete the connections and plug the connectors into the Amp/Relay Module.

Outlets

This system offers 8 Outlets. Each of these outlets provides +12VDC with a maximum circuit capacity of 8 Amps. If the user desires, the system can be wired so that a 9th outlet is available (instead of a Dry Contact Relay).

Icon Driver (Item 5-7)

This output provides +12VDC with a maximum circuit capacity of 250 mA. This output becomes active whenever a siren tone is active.

Siren Speaker (Items 6-1 & 6-2)

1. Route the wires from 6-1 and 6-2 from the amp/relay module to the siren speaker.
2. Connect 6-1 to the ORG speaker wire (speaker high).
3. Connect 6-2 wire to BRN speaker wire (speaker low).

NOTE: For dual speaker installation, connect the second speakers wires to the same destinations as the first speakers wires (see page 7).

Radio Rebroadcast (Items 5-1 & 5-6)

The wires from 5-1 & 5-6 are used to connect your two-way radio's external speaker for radio re-broadcast. This is an optional connection and will not effect the other operations.

Note: Radio re-broadcast will NOT work with amplified remote speakers! If your remote speaker is amplified (i.e.: contains a power amp circuit in the speaker assembly), do not enable the radio re-broadcast feature.

1. Locate the two wires that connect the external speaker to the two-way radio, cut one of them and splice one of the BLU wires into this circuit.
2. Cut the remaining speaker wire and splice the remaining BLU wire into this circuit.

Backlighting (Item 5-2)

1. Route the wire from 5-2 to the vehicle's marker light circuit.
2. Splice this wire into this circuit to enable the control head backlighting to be active whenever the vehicle's marker light is active.

Inputs

Horn Ring Inputs (Item 5-4 or 5-9)

If Hands Free siren control is desired, the vehicle horn ring circuit must be integrated into the siren system as shown in the wiring diagrams on page 7.

LCPA Low Current Power Activation Inputs (5-3 or 5-8)

If desired, this system can be switched on (or activated) using Low Current Power Activation (LCPA) inputs. This is accomplished by connecting the appropriate LCPA input wire to the desired signal. If the polarity of the signal to be used is Positive (+), use LCPA Input 5-3. If the polarity of the signal is Negative (-), use LCPA Input 5-8.

Park-Kill (Optional Connection) (Item 5-5 or 5-10)

This feature will automatically suspend an active siren tone when the transmission is shifted into Park. If this feature is desired, the installer must first determine if the signal wire from the transmission neutral safety switch is switching the positive or negative side of the circuit. Use 5-5 if the signal is switching Positive. Use 5-10 if the signal is switching Negative.

Using 18 to 22 gage wire, extend and connect the appropriate wire from the amp/relay module to the vehicle's transmission neutral safety switch signal wire.

Hands-Free Siren (Items 33 & 37) (Optional)

Hands-Free connection allows siren tones to be initiated and controlled using the vehicle horn ring button. Using a customer supplied relay capable of handling the current of your vehicle horn, connect as shown on page 7.

PA Volume Adjustment

Locate the PA adjustment pot (potentiometer) on the side of the amp/relay module. Using a small, flat-blade screwdriver, set the potentiometer to its middle position. With the system on, activate the PTT (Push To Talk) feature on the optional microphone. Adjust the potentiometer until a satisfactory PA volume level is achieved using a normal speaking voice.

Radio Repeat Volume Adjustment

To Adjust the Radio Repeat Levels: Before placing this unit into service, the Radio Repeat output volume must be adjusted to satisfactory operating levels. To adjust this level, a small, flat blade screwdriver is needed. Locate the Radio Repeat adjustment potentiometer on the side of the amp/relay module. Set the volume of the vehicle's two-way radio to it's normal operating level. Press the RAD button on the control head to activate Radio Repeat. As incoming transmissions are received, adjust the Radio Repeat potentiometer to set the desired level. Turn the potentiometer clockwise to increase the level and counter-clockwise to decrease the level.

Amp/Relay Module Fuses

For ease of access, all of the amp/relay module fuses are accessible from outside the case.

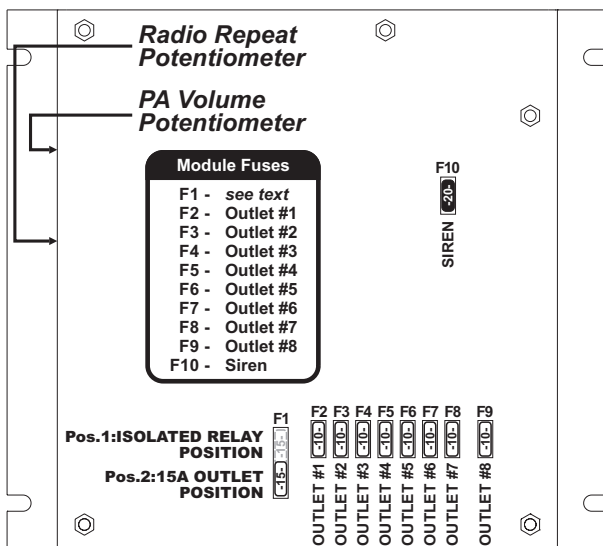

Isolated Relay (Outlet 9)

The position of Fuse F1 determines the function of wires 6-3, 6-4 & 6-5. When the fuse is in Position 1, these wires act as a Isolated 15 Amp Relay. When the fuse is in Position 2, wires 6-3 and 6-4 act as Outlet #9. Refer to the schematic shown for the electronic properties of this circuit.

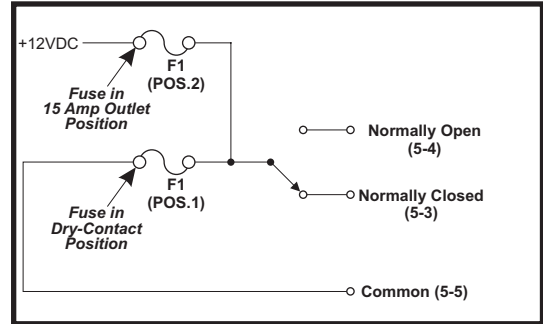

Hand-held Controller Default Push Button Operation

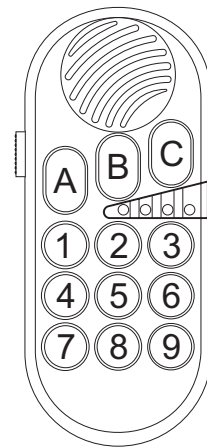

- A - Outlet 1
- B - Outlets 1 & 2
- C - Outlets 1, 2 & 3*
- 1 - H/F (Outlet 9)
- 2 - MAN
- 3 - Air Horn
- 4 - Siren
- 5 - Radio
- 6 - Alley (Outlets 4 & 5)
- 7 - Outlet 6
- 8 - Outlet 7
- 9 - Outlet 8

Button A - This button activates Outlet 1.

Button B - This button activates Outlets 1 & 2.

Button C - This button activates Outlets 1, 2 & 3. NOTE: If Dip Switch 3 is in the ON position, this button will also turn the siren on.

Button 1 - This button puts the siren into Hands Free mode. In this mode, the WAIL tone is initiated by either pressing the **Horn Ring** or **Button 2** (see Button 2 for details).

Button 1 also activates Outlet 9.

Button 2 - While **Button 1** is active, pressing this button (or the horn ring) will produce a WAIL tone. Subsequent presses of the horn ring or button 2 will cycle the tone between WAIL and YELP. Two rapid presses will stop the tone. While **Button 1** is inactive, pressing Button 2 will generate a tone that will ramp up to and sustain a specific pitch until this button is released.

Button 3 - This button will broadcast the Air-Horn tone until it is released. This tone will over-ride all other siren tones.

Button 4 - This button activates the WAIL tone. A second press will stop that tone. Pressing button 2 will change the tone to YELP.

Button 5 - This button will rebroadcast your radio output through the siren speaker. This button is enabled by default.

Button 6 - This button activates Outlets 4 and 5. This button cycles in the following manner:

- 1st Press - Activates Outlet 4
- 2nd Press - Activates Outlet 5
- 3rd Press - Activates Outlets 4 & 5
- 4th Press - Deactivates Outlets 4 & 5

Button 7 - This button activates Outlet 6.

Button 8 - This button activates Outlet 7.

Button 9 - This button activates Outlet 8.

Multi-Function De-activation - To turn off all active operations, press and hold any active keypad button for at least 2 seconds.

Dip Switch Functions

The Amp/Relay module contains a bank of 4 dip switches. The function of each switch is as follows:

DS1 - This dip switch must remain in the ON position at all times.

DS2 - This switch determines the audio characteristics of the WAIL siren tone. If the DS2 is in the OFF (default) position, an 'electronic' siren tone will be generated. If DS2 is in the ON position, a simulated 'mechanical' siren tone will be generated.

DS3 - This switch controls the siren pursuit tone. If DS3 is in the ON position, the WAIL tone is generated when button 3 is pressed. If DS3 is in the OFF position, no siren tone is generated when button 3 is pressed.

DS4 - This switch determines the method that will be used to turn the siren system on. If the switch is in the ON position, the system is turned on by switching the high-current main power lines (1-3 & 1-4). If this is desired, a switch sized to handle the entire current load must be installed in-line with both 1-3 and 1-4.

If the DS4 is in OFF position, the system is turned on via the LCPA wire (5-3 or 5-8).

NOTE: The controller is shipped without any button decals installed. Do not place button decals directly onto the buttons. Install a plate onto each button first and then adhere the desired button decal onto that plate.

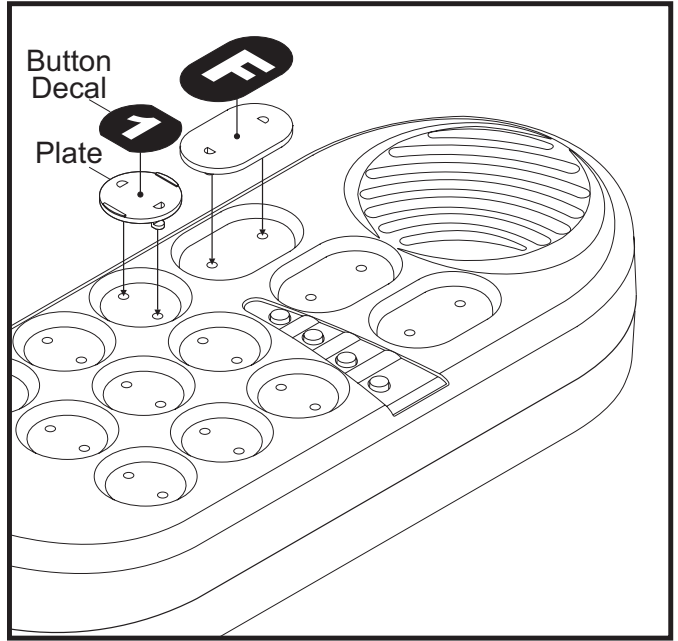

Programming

The button functions of the controller may be reprogrammed using the HHS 2200 Plus Configuration software. The Amp/Relay module must first be connected to the programming computer via the USB Port.

Refer to the online help provided with the software for programming procedures.

Wire Gauge Calculation Chart

Maximum Current Draw Through The Wire

Wire Gauge	5 Amps	10 Amps	15 Amps	20 Amps	25 Amps	30 Amps	35 Amps	40 Amps	45 Amps	50 Amps
	22 AWG	6 Feet	3 Feet	Insufficient	Insufficient	Insufficient	Insufficient	Insufficient	Insufficient	Insufficient
20 AWG	9.5 Feet	5 Feet	3 Feet	Insufficient	Insufficient	Insufficient	Insufficient	Insufficient	Insufficient	Insufficient
18 AWG	15 Feet	7.5 Feet	5 Feet	4 Feet	3 Feet	Insufficient	Insufficient	Insufficient	Insufficient	Insufficient
16 AWG	24.5 Feet	12 Feet	8 Feet	6 Feet	5 Feet	4 Feet	3.5 Feet	3 Feet	Insufficient	Insufficient
14 AWG	39 Feet	19.5 Feet	13 Feet	9.5 Feet	8 Feet	6.5 Feet	5.5 Feet	5 Feet	4.5 Feet	4 Feet
12 AWG	62 Feet	31 Feet	20.5 Feet	15.5 Feet	12.5 Feet	10.5 Feet	9 Feet	7.5 Feet	7 Feet	6 Feet
10 AWG	98 Feet	49 Feet	32.5 Feet	24.5 Feet	19.5 Feet	16.5 Feet	14 Feet	12.5 Feet	11 Feet	10 Feet
8 AWG	156 Feet	78 Feet	52 Feet	39 Feet	31 Feet	26 Feet	22.5 Feet	19.5 Feet	17.5 Feet	15.5 Feet
6 AWG	248.5 Feet	124 Feet	82.5 Feet	62 Feet	49.5 Feet	41.5 Feet	35.5 Feet	31 Feet	27.5 Feet	25 Feet
4 AWG	395 Feet	197.5 Feet	131 Feet	98.5 Feet	79 Feet	66 Feet	56.5 Feet	49.5 Feet	44 Feet	39.5 Feet
2 AWG	629 Feet	314 Feet	209 Feet	157 Feet	125.5 Feet	104.5 Feet	89.5 Feet	78.5 Feet	69.5 Feet	63 Feet

Maximum Current Draw Through The Wire

Wire Gauge	55 Amps	60 Amps	65 Amps	70 Amps	75 Amps	80 Amps	85 Amps	90 Amps	95 Amps	100 Amps
	22 AWG	Insufficient	Insufficient	Insufficient	Insufficient	Insufficient	Insufficient	Insufficient	Insufficient	Insufficient
20 AWG	Insufficient	Insufficient	Insufficient	Insufficient	Insufficient	Insufficient	Insufficient	Insufficient	Insufficient	Insufficient
18 AWG	Insufficient	Insufficient	Insufficient	Insufficient	Insufficient	Insufficient	Insufficient	Insufficient	Insufficient	Insufficient
16 AWG	Insufficient	Insufficient	Insufficient	Insufficient	Insufficient	Insufficient	Insufficient	Insufficient	Insufficient	Insufficient
14 AWG	3.5 Feet	3 Feet	3 Feet	3 Feet	Insufficient	Insufficient	Insufficient	Insufficient	Insufficient	Insufficient
12 AWG	5.5 Feet	5 Feet	5 Feet	4.5 Feet	4 Feet	4 Feet	3.5 Feet	3.5 Feet	3.5 Feet	3 Feet
10 AWG	9 Feet	8 Feet	7.5 Feet	7 Feet	6.5 Feet	6 Feet	6 Feet	5.5 Feet	5 Feet	5 Feet
8 AWG	14 Feet	13 Feet	12 Feet	11 Feet	10.5 Feet	10 Feet	9 Feet	8.5 Feet	8 Feet	8 Feet
6 AWG	22.5 Feet	20.5 Feet	19 Feet	17.5 Feet	16.5 Feet	15.5 Feet	14.5 Feet	14 Feet	13 Feet	12.5 Feet
4 AWG	36 Feet	33 Feet	30.5 Feet	28 Feet	26.5 Feet	24.5 Feet	23 Feet	22 Feet	21 Feet	19.5 Feet
2 AWG	57 Feet	52.5 Feet	48.5 Feet	45 Feet	42 Feet	39 Feet	37 Feet	35 Feet	33 Feet	31.5 Feet

Front Panel Wiring

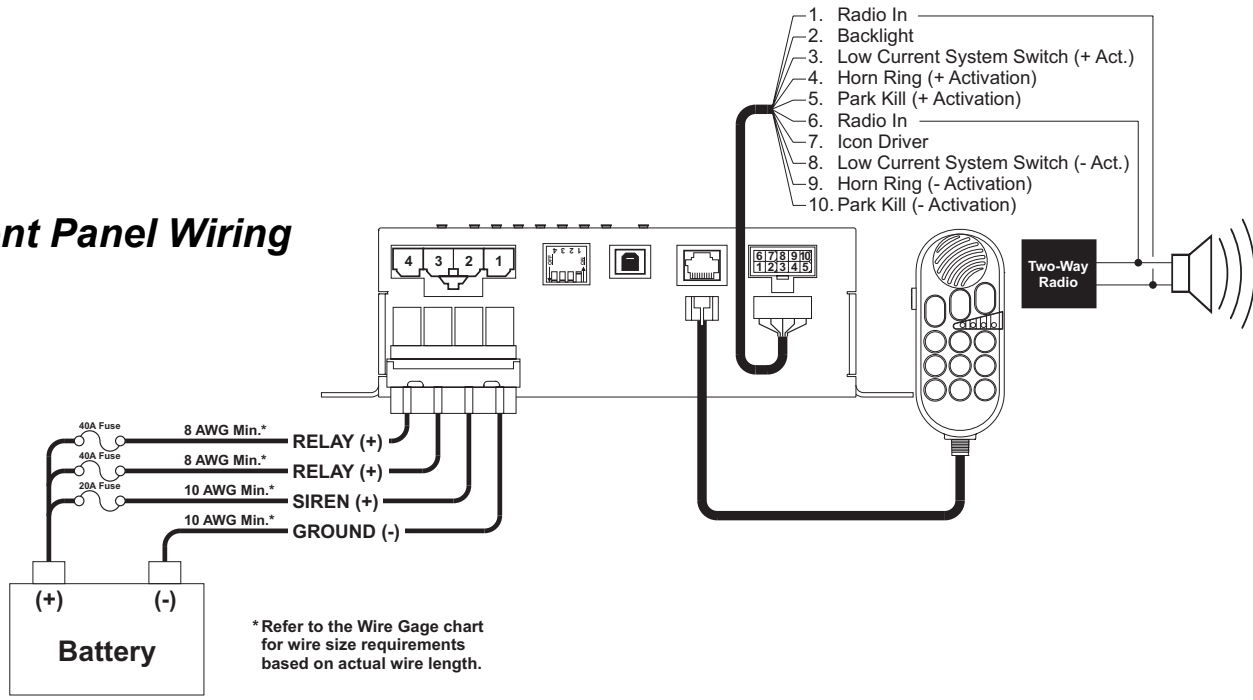

Rear Panel Wiring (example 1)

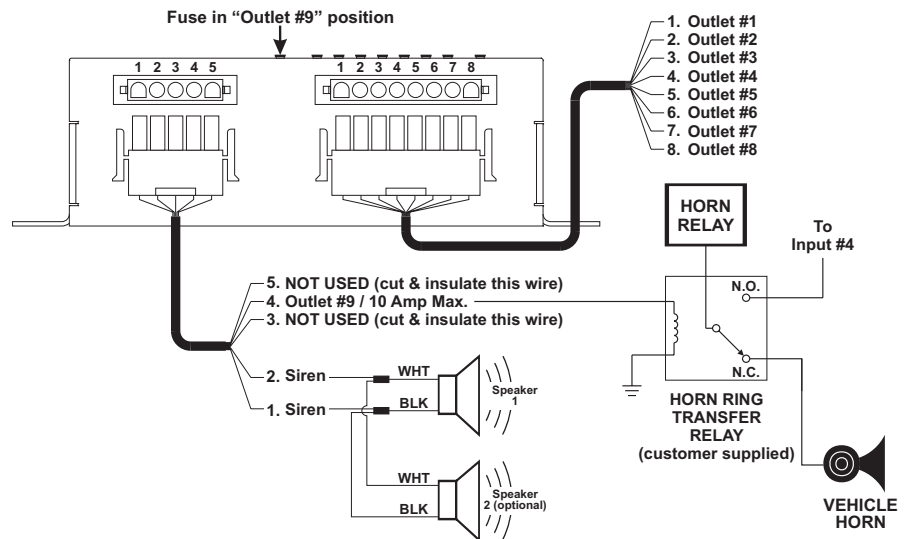

Rear Panel Wiring (example 2)

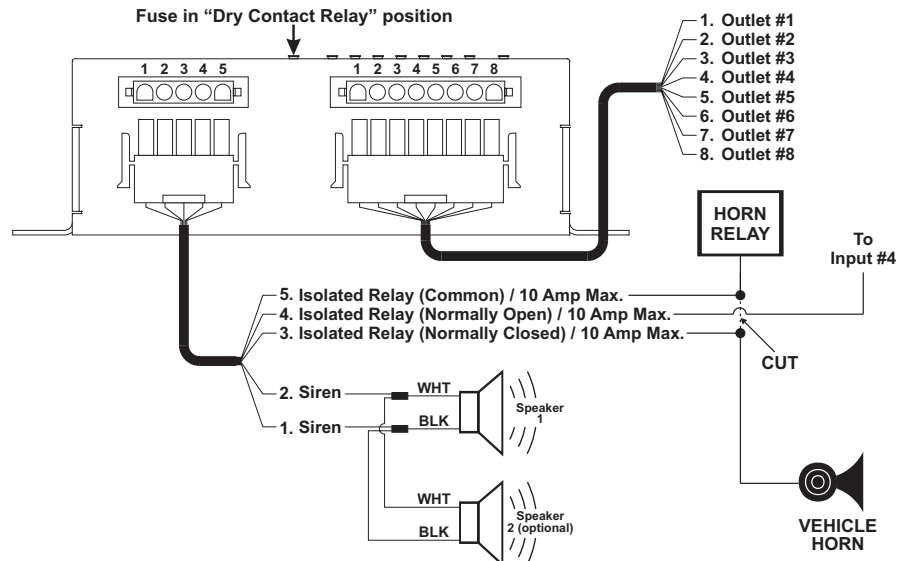

Amp/Relay Module Input/Output Identification

- Item #1**
 1-1 Ground (-)
 1-2 Siren (+)
 1-3 Relay (+)
 1-4 Relay (+)

- Item #2**
 2-1 Dip Switch #1
 2-2 Dip Switch #2
 2-3 Dip Switch #3
 2-4 Dip Switch #4

- Item #3**
 USB Port

- Item #4**
 Controller Port

- Item #5**
 5-1 Radio In
 5-2 Backlight
 5-3 Low Current System Switch (+ Activation)
 5-4 Horn Ring (+ Activation)
 5-5 Park Kill (+ Activation)
 5-6 Radio In
 5-7 Icon Driver
 5-8 Low Current System Switch (- Activation)
 5-9 Horn Ring (- Activation)
 5-10 Park-Kill (- Activation)

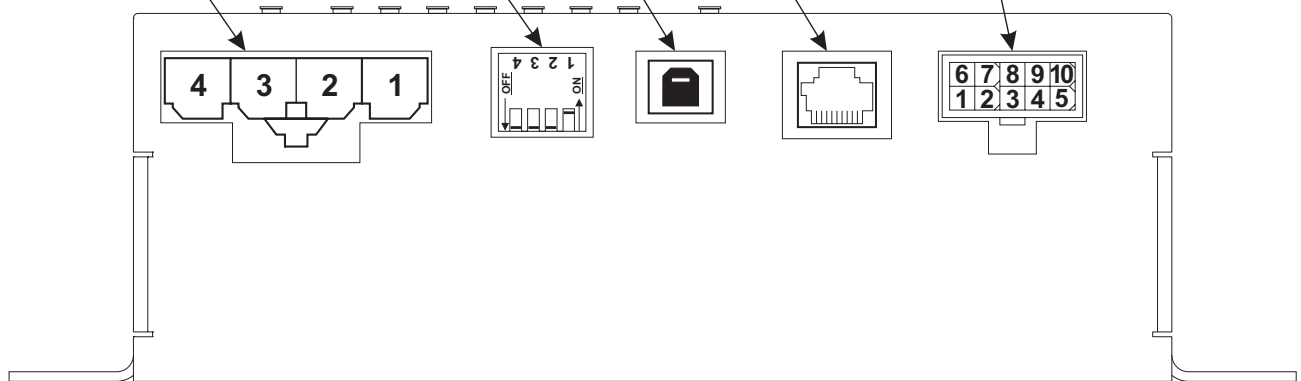

- Item #6**
 6-1 Siren
 6-2 Siren
 6-3 Isolated Relay (Normally Closed)
 6-4 Isolated Relay (Normally Open)
 6-5 Isolated Relay (Common)

- Item #7**
 7-1 Outlet #1
 7-2 Outlet #2
 7-3 Outlet #3
 7-4 Outlet #4
 7-5 Outlet #5
 7-6 Outlet #6
 7-7 Outlet #7
 7-8 Outlet #8

