

WHELEN[®] ENGINEERING COMPANY INC.

51 Winthrop Road
 Chester, Connecticut 06412-0684
 Phone: (860) 526-9504
 Fax: (860) 526-4078
 Internet: www.whelen.com
 Sales e-mail: autosale@whelen.com
 Canadian Sales e-mail: autocan@whelen.com
 Customer Service e-mail: custserv@whelen.com

Installation Guide: SA315 Siren Speaker Mounting Bracket 2005 Dodge Magnum or Charger

DANGER! Sirens produces extremely loud emergency warning tones! Exposure to these tones without proper and adequate hearing protection, could cause ear damage and/or hearing loss! The Occupational Safety & Health Administration (www.osha.gov) provides information necessary to determine safe exposure times in Occupational Noise Exposure Section 1910.95. Until you have determined the safe exposure times for your specific application, operators and anyone else in the immediate vicinity should be required to wear an approved hearing protection device. **FAILURE TO FOLLOW THIS RECOMMENDATION COULD CAUSE HEARING LOSS!**

Safety First

This document provides all the necessary information to allow your Whelen product to be properly and safely installed. Before beginning the installation and/or operation of your new product, the installation technician and operator must read this manual completely. Important information is contained herein that could prevent serious injury or damage.

- Proper installation of this product requires the installer to have a good understanding of automotive electronics, systems and procedures.
- If mounting this product requires drilling holes, the installer **MUST** be sure that no vehicle components or other vital parts could be damaged by the drilling process. Check both sides of the mounting surface before drilling begins. Also de-burr any holes and remove any metal shards or remnants. Install grommets into all wire passage holes.
- If this manual states that this product may be mounted with suction cups, magnets, tape or Velcro™, clean the mounting surface with a 50/50 mix of isopropyl alcohol and water and dry thoroughly.
- Do not install this product or route any wires in the deployment area of your air bag. Equipment mounted or located in the air bag deployment area will damage or reduce the effectiveness of the air bag, or become a projectile that could cause serious personal injury or death. Refer to your vehicle owners manual for the air bag deployment area. The User/Installer assumes full responsibility to determine proper mounting location, based on providing ultimate safety to all passengers inside the vehicle.
- For this product to operate at optimum efficiency, a good electrical connection to chassis ground must be made. The recommended procedure requires the product ground wire to be connected directly to the **NEGATIVE (-)** battery post.
- If this product uses a remote device to activate or control this product, make sure this control is located in an area that allows both the vehicle and the control to be operated safely in any driving condition. **DO NOT ATTEMPT TO ACTIVATE OR CONTROL THIS DEVICE IN A HAZARDOUS DRIVING SITUATION.**
- It is recommended that these instructions be stored in a safe place and referred to when performing maintenance and/or reinstallation of this product.
- **FAILURE TO FOLLOW THESE SAFETY PRECAUTIONS AND INSTRUCTIONS COULD RESULT IN DAMAGE TO THE PRODUCT OR VEHICLE AND/OR SERIOUS INJURY TO YOU AND YOUR PASSENGERS!**

ACTIVATION OF THIS SIREN MAY DAMAGE UNPROTECTED EARS!	
 Wear Protection!	CAUTION Loud siren noise can cause hearing damage and/or loss. Refer to OSHA Section 1910.95 prior to putting ANY siren into service!

For warranty information regarding this product, visit www.whelen.com/warranty

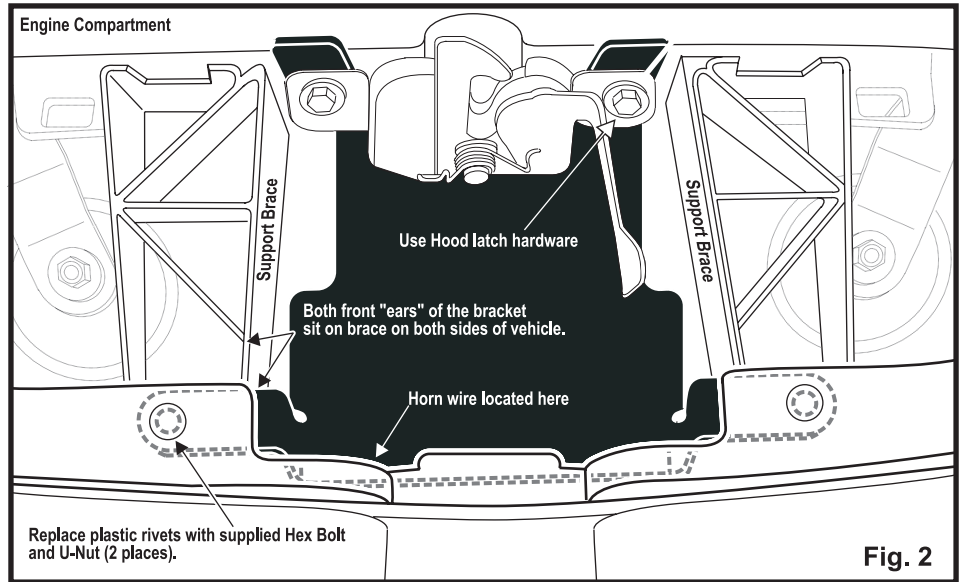
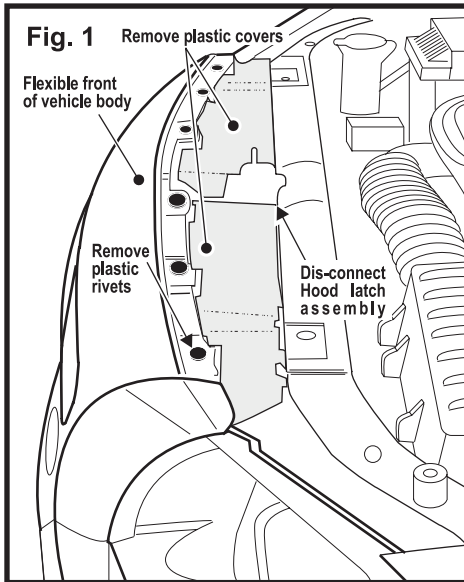

Installation: 2005 Dodge Charger or Magnum

1. Remove the 2 plastic covers that protect the front area under the hood (Fig. 1). They snap into or out of the vehicle.
2. Remove the 2 bolts that hold the hood latch assembly on and set it aside (do not disconnect the cables). Unplug the horn wire and place the wire out of the way (Figs. 1 & 2).
3. Mount speaker to bracket (Fig. 3).
4. Remove all the plastic rivets from the top of the front of the body of the vehicle, then pull the body toward the front of the vehicle (the body is flexible). Slide the 2 U-Nuts onto the support braces (Fig. 4) and place the bracket (with siren attached) on top of the U-Nuts. The front "ears" of the bracket rest on the two U-Nuts which clip onto the support braces (Fig. 4). The rear of the bracket will mount behind the hood latch assembly using the hood latch's mounting hardware (Fig. 2).
5. Be sure all the hood latch cables are properly located, then secure the hood latch assembly over the rear of the bracket using the hood latch assemblies two bolts. **IMPORTANT: Make sure the two bolt heads line up with the two indentations on the hood latch assembly made by the bolts original position, so that the hood latch assembly reinstalls in the same position and lines up properly with the hood.**
6. Re-attach the horn wire then replace the plastic rivets you removed in step 5, except the 2 rivets that line up with the front mounting holes of the siren bracket. Replace those rivets with the supplied mounting hardware (Fig 4) securing the front of the bracket to the vehicle.
7. First trim some plastic off of each of the two protective covers you removed in step 1 (Fig. 5) to accommodate the two ears on the front of the bracket, then snap the two plastic covers back on.
8. Extend WHITE (positive) and BLACK (negative) speaker wires to your siren amplifier and connect as shown in the amplifiers instructions.

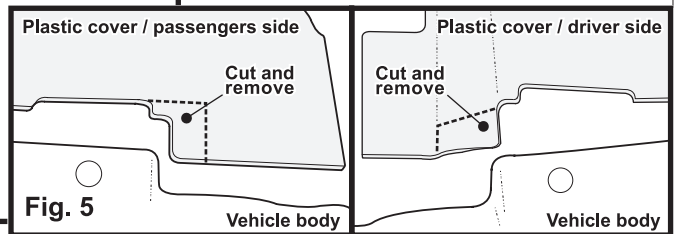
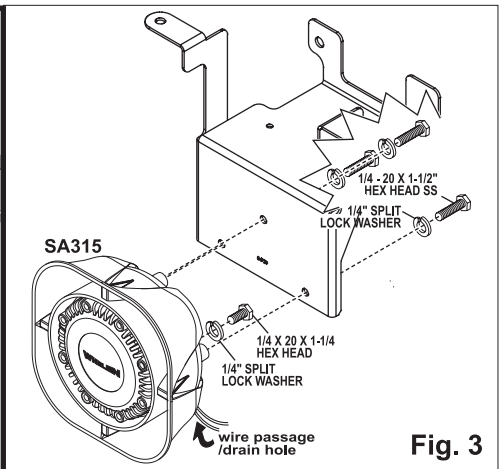
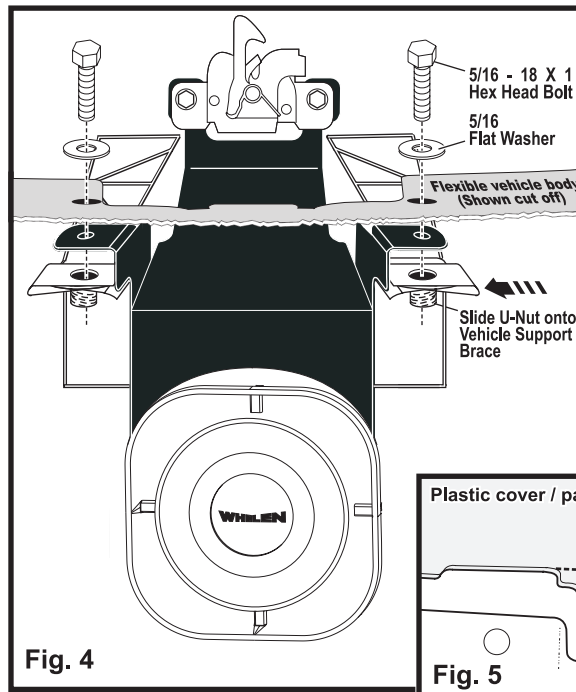

Caution: It is the responsibility of the installation technician to make sure that the installation and operation of this product will not interfere with or compromise the operation or efficiency of any vehicle equipment! Before returning the vehicle to active service, visually confirm the proper operation of this product, as well as all vehicle components/equipment.

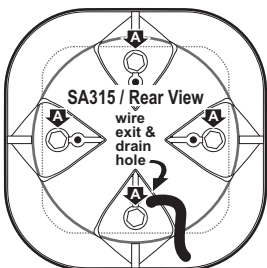

The SA315 siren speaker mounting kit comes with 3 long bolts (1/4-20 X 1-1/2" Hex Head). The longer bolts are needed to go through the mounting bracket, the siren housing and into the siren driver. They will replace 3 of the 4 shorter bolts ("A") that now secure the siren driver to the speaker housing. Your speaker is shipped with 2 of the shorter bolts installed. A short bolt must be used in the hole that does not go through the bracket so it will properly secure the driver to the housing. If you need to remove all 4 bolts at once be sure to hold the driver securely in place.

IMPORTANT: For drainage purposes, the speaker must be oriented so that the wire passage hole is in the "6 o'clock" position (closest to the road). This is also the drain hole for the siren. Improper orientation will result in premature driver failure and void the product warranty.

