

WHELEN[®]

ENGINEERING COMPANY INC.

51 Winthrop Road
 Chester, Connecticut 06412-0684
 Phone: (860) 526-9504
 Fax: (860) 526-4078
 Internet: www.whelen.com
 Sales e-mail: autosale@whelen.com
 Canadian Sales e-mail: autocan@whelen.com
 Customer Service e-mail: custserv@whelen.com

Installation Guide: SA315 Siren Speaker Mounting Bracket 2006 Chevrolet Impala SAK21

DANGER! Sirens produces extremely loud emergency warning tones! Exposure to these tones without proper and adequate hearing protection, could cause ear damage and/or hearing loss! The Occupational Safety & Health Administration (www.osha.gov) provides information necessary to determine safe exposure times in Occupational Noise Exposure Section 1910.95. Until you have determined the safe exposure times for your specific application, operators and anyone else in the immediate vicinity should be required to wear an approved hearing protection device. **FAILURE TO FOLLOW THIS RECOMMENDATION COULD CAUSE HEARING LOSS!**

Safety First

This document provides all the necessary information to allow your Whelen product to be properly and safely installed. Before beginning the installation and/or operation of your new product, the installation technician and operator must read this manual completely. Important information is contained herein that could prevent serious injury or damage.

- Proper installation of this product requires the installer to have a good understanding of automotive electronics, systems and procedures.
- If mounting this product requires drilling holes, the installer **MUST** be sure that no vehicle components or other vital parts could be damaged by the drilling process. Check both sides of the mounting surface before drilling begins. Also de-burr any holes and remove any metal shards or remnants. Install grommets into all wire passage holes.
- If this manual states that this product may be mounted with suction cups, magnets, tape or Velcro™, clean the mounting surface with a 50/50 mix of isopropyl alcohol and water and dry thoroughly.
- Do not install this product or route any wires in the deployment area of your air bag. Equipment mounted or located in the air bag deployment area will damage or reduce the effectiveness of the air bag, or become a projectile that could cause serious personal injury or death. Refer to your vehicle owners manual for the air bag deployment area. The User/Installer assumes full responsibility to determine proper mounting location, based on providing ultimate safety to all passengers inside the vehicle.
- For this product to operate at optimum efficiency, a good electrical connection to chassis ground must be made. The recommended procedure requires the product ground wire to be connected directly to the **NEGATIVE (-)** battery post.
- If this product uses a remote device to activate or control this product, make sure this control is located in an area that allows both the vehicle and the control to be operated safely in any driving condition. **DO NOT ATTEMPT TO ACTIVATE OR CONTROL THIS DEVICE IN A HAZARDOUS DRIVING SITUATION.**
- It is recommended that these instructions be stored in a safe place and referred to when performing maintenance and/or reinstallation of this product.
- **FAILURE TO FOLLOW THESE SAFETY PRECAUTIONS AND INSTRUCTIONS COULD RESULT IN DAMAGE TO THE PRODUCT OR VEHICLE AND/OR SERIOUS INJURY TO YOU AND YOUR PASSENGERS!**

**ACTIVATION OF THIS
 SIREN MAY DAMAGE
 UNPROTECTED EARS!**



CAUTION

Loud siren noise can cause hearing damage and/or loss. Refer to OSHA Section 1910.95 prior to putting ANY siren into service!

For warranty information regarding this product, visit www.whelen.com/warranty

Installation:

CAUTION: Mounting will require drilling. It is absolutely necessary to be sure that no vehicle components will be damaged in the process. Check both sides of the mounting surface before starting.

IMPORTANT: For drainage purposes, the speaker must be oriented so the wire passage/drain hole is in the “6 o'clock” position (closest to the road). Improper mounting will result in premature driver failure and void the product warranty.

The SA315 mounting kit comes with 3 long bolts (1/4-20 X 1-1/2” Hex Head SS) necessary to go through the mounting bracket, the siren housing and into the siren driver. They will replace 3 of the 4 shorter bolts (“A”) that now secure the siren driver to the speaker housing. Your speaker is shipped with 2 of the shorter bolts installed. A short bolt must be used in the hole that does not go through the bracket so it will properly secure the driver to the housing. If you need to remove all 4 bolts at once be sure to hold the driver securely in place (FIG. 3).

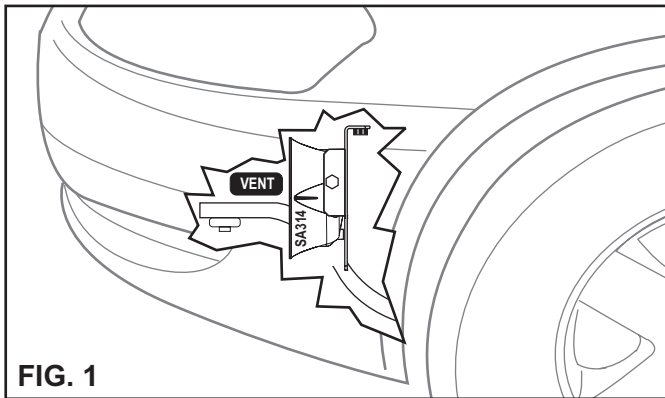
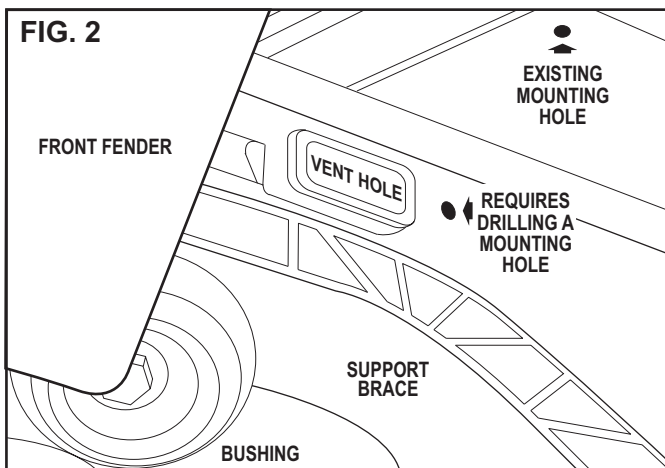

FIG. 1

1. To access the speaker bracket mounting area, remove the driver-side headlight assembly (refer to the vehicle service manual for proper removal procedure). **Do not mount this bracket on the passenger-side of the vehicle.**
2. With the headlight assembly removed, locate the mounting area shown in figures 1 & 2. The speaker bracket mounts as shown.



View from bottom of vehicle with splash shield removed. (Removal is not necessary for installation)

3. The upper mounting bolt will use an existing hole in the vehicle, while the side mounting bolt will require a 3/8” mounting hole to be drilled. Secure the bracket using the upper mounting hole and the hardware provided as shown in Fig. 4.

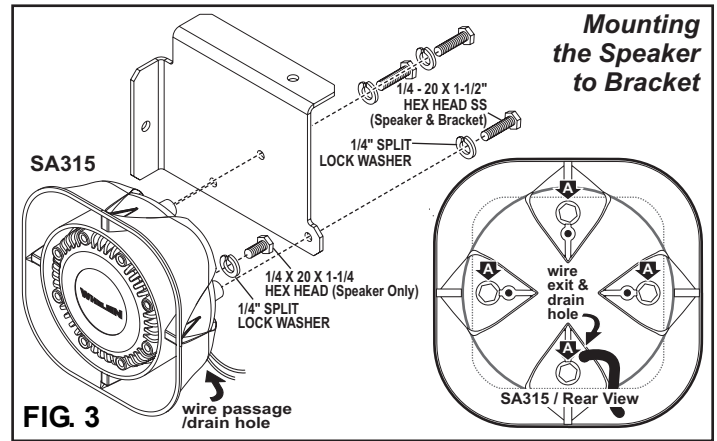

FIG. 3

IMPORTANT NOTE: Be sure the speaker bracket is perpendicular to the road so that the speaker will project siren tones in a direction parallel with the road.

4. With the bracket secured, mark the location of the side mounting hole then remove the bracket and drill the mounting hole.
5. Mount the speaker onto the bracket using the supplied hardware then mount the speaker/bracket securely to the vehicle.

NOTE: When installing the side mounting bracket hardware, the backside of the mounting hole can be accessed through the adjacent vent hole. This allows the nut and lock washer to be held in place while installing the bolt.

6. Extend the WHITE (positive) and BLACK (negative) speaker wires to your amplifier and connect as shown in the amplifiers instructions. Test the speaker to confirm proper operation.
7. Re-install the headlight assembly to complete this installation. Test all vehicle components and equipment for proper operation before returning the vehicle to service.

IMPORTANT! It is the responsibility of the installation technician to make sure that the installation and operation of this product will not interfere with or compromise the operation or efficiency of any vehicle equipment!

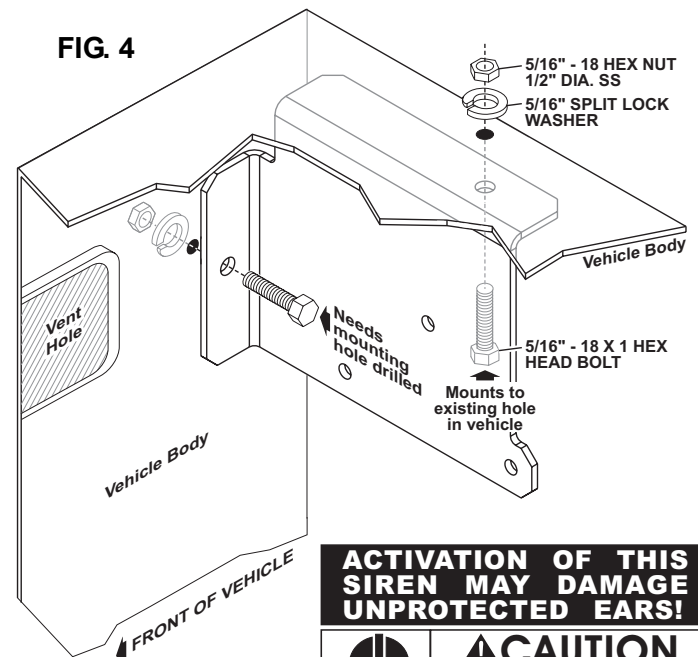

FIG. 4

ACTIVATION OF THIS SIREN MAY DAMAGE UNPROTECTED EARS!



CAUTION
Loud siren noise can cause hearing damage and/or loss. Refer to OSHA Section 1910.95 prior to putting ANY siren into service!